

Malema Electromagnetic Flowmeter Series MLDZ

Malema's electromagnetic flowmeter is an advanced microprocessor based instrument suitable for measuring flow of conductive liquids used in chemical, pharmaceutical, refineries, power, steel, pulp & paper, waste water and HVAC industries. Series MLDZ is the latest electromagnetic flow meter offered by Malema Sensors based on its two decades of flow measurement and control experience.

Each flow meter is individually calibrated and passes through a rigorous inspection program laid out by the Malema inspection team. Malema engineers will help you select appropriate models for your challenging applications. This affordable high quality flow meter combined with Malema's excellent customer support offers you the best of the flow measurement solutions in the market.

Principle of measurement:

Malema's Electromagnetic flowmeters are based on Faraday's law of electromagnetic induction principle. A pulsed DC current is passed to the coil surrounding the flow tube to create a magnetic field in the flow path. When a conductive liquid, slurry or paste passing through the tube cuts this magnetic field a voltage proportional to the velocity of the medium is produced. Electrodes inside the flow tube pick up the voltage which is then processed in the signal converter for local display and signal transmission purposes.

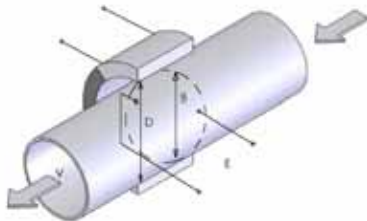

$$E = BLV$$

$$Q = EA$$

Where
 B is the magnetic field
 L is the distance between electrodes
 V is the velocity of the medium
 A is the area of cross section of the tube
 E is the voltage induced
 Q is the volume flow rate



Applications:

- Water and waste water
- Chemicals, acids and alkalis
- Pulp and Slurries

Features and Benefits:

- Flow through construction with no obstruction to the flow: Low pressure drop, low wear and tear
- Flow accuracy is unaffected by the changes in the physical parameters like, pressure, temperature, density or viscosity.
- High accuracy and reliability
- Low cost of ownership
- Wide rangeability
- Wide choice of liner and electrodes to meet application requirement
- All flow meters are individually wet calibrated

General Specification:

Primary head (flow tube) specification:

Size:	½" to 62" and DN 10 to DN 1600
End Connection:	Flanged to ANSI, DIN standard
Pressure rating:	DN 10 to DN 50; ½" to 2" – 40 Kg/cm ² DN 65 to DN 150; 2 ½ "to 6" – 16 Kg/cm ² DN 200 to DN 1000; 8" to 40" – 10 kg/cm ² DN 1200 to DN 1600; 48" to 62" – 6 kg/cm ²
	* For higher pressures for meter size up to 6"/DN150 please refer factory for details.
Temperature rating:	Compact Version: PTFE (-25 deg C to +120 Deg C) Neoprene (<80 deg C) Polyurethane (< 45 deg C) Remote version: PTFE (-25 to 180 deg C) Neoprene (<80 deg C) Polyurethane (< 45 deg C)
Materials:	Flow tube: SS 304 Flanges: Steel Housing: Sheet Steel
Liner material:	PTFE – for sizes up to DN 1000; 40" Neoprene – for sizes DN 25 to DN 1600; 1" to 62" Polyurethane- for sizes DN 25 to DN 1200; 1" to 48"
Electrodes:	SS 316 Ti, Hastalloy C, Hastalloy B, Titanium, Tantalum, Platinum

Signal Converter (flow transmitter):

Type:	Microprocessor based; remote and compact options available
Display:	Local LCD board with programming keys
Accuracy:	+/-0.5% of the reading
Power supply:	90-265 V ac 48-60 Hz
Output:	Current: 0/4- 20mA (max. 750 ohms) Frequency: 1-5000 Hz Pulse: 5000 p/sec
Digital outputs (optional):	RS 485/ RS 232 (Please refer factory for details)
Protection:	IP 65
Temperature limits:	-10 deg C to +55 deg C
Humidity:	< 85% RH
Ex-Proof version:	Available (FM approval pending)

Electrical Connections:

Remote Version:

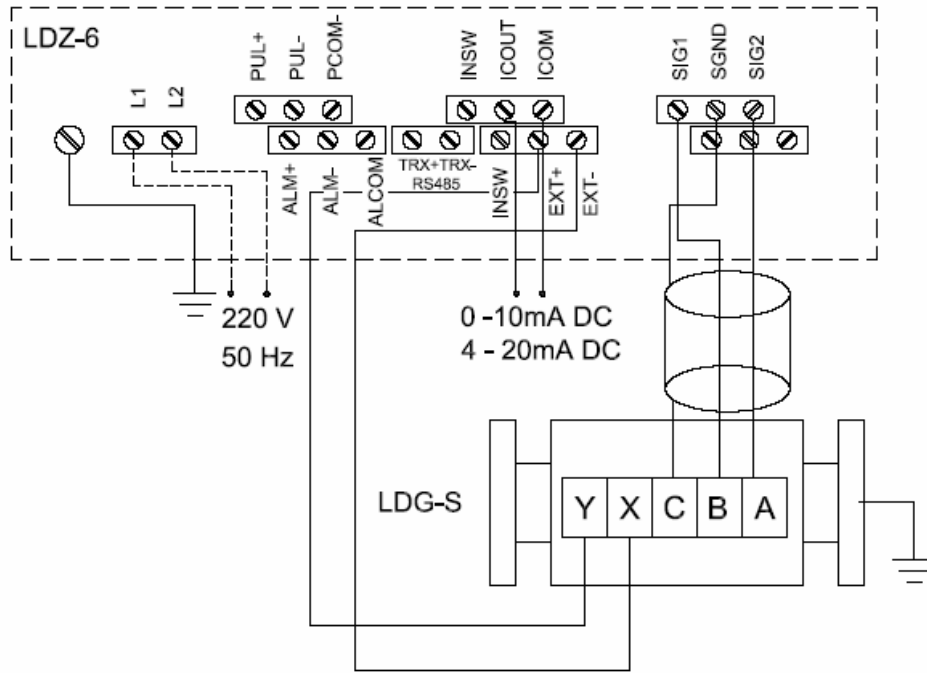

Compact Version:

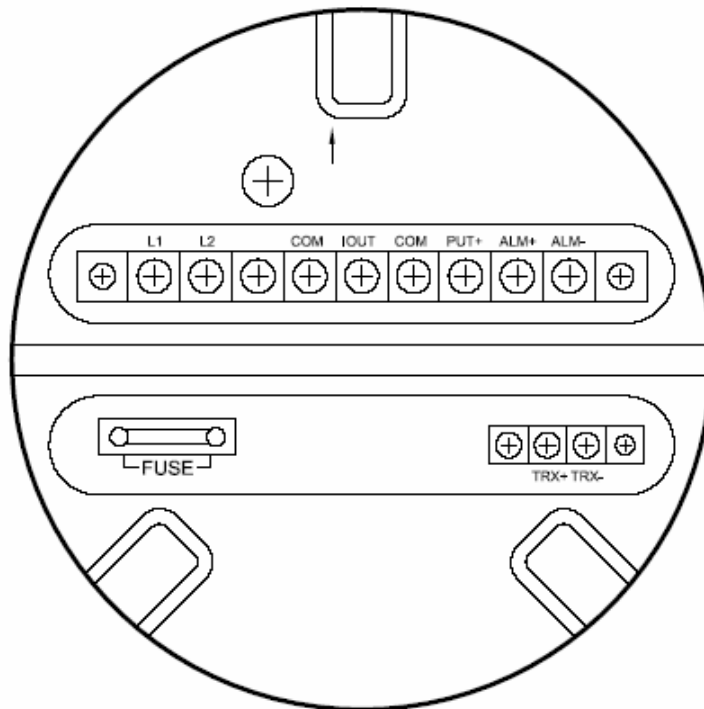

Dimensions:

Compact Version:

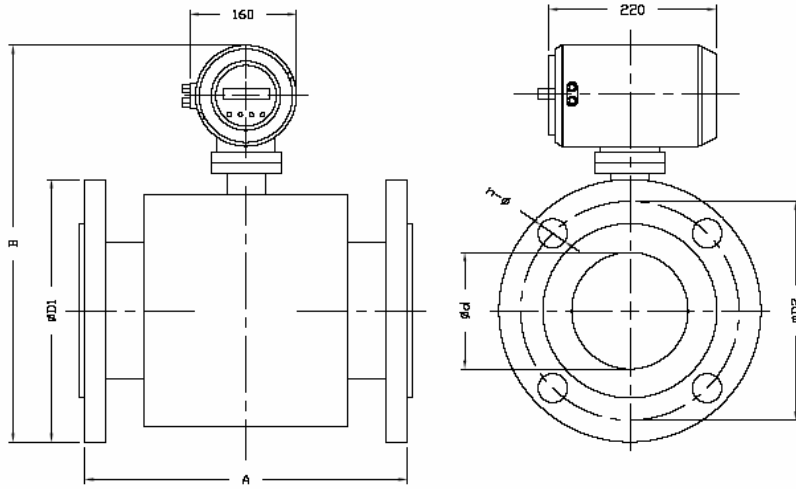

Remote Version:

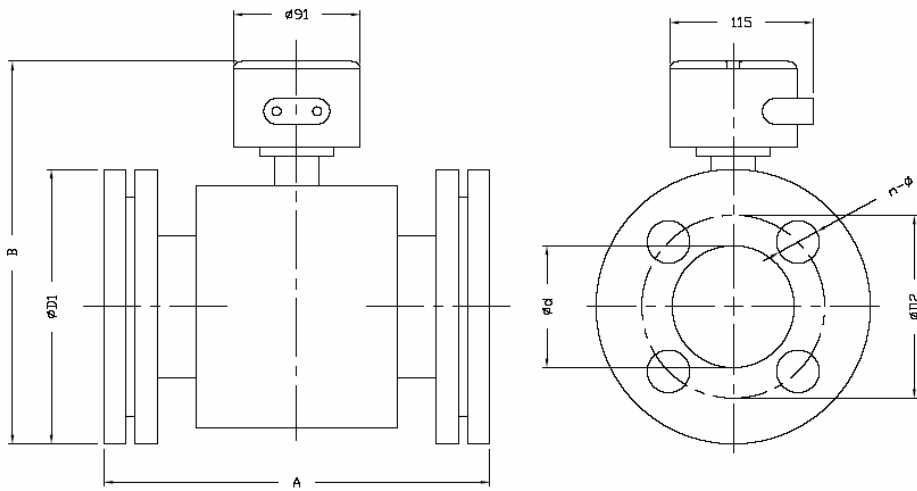

Dimensions: in mm

Size (in mm)	Liner			B	D1	Approx. Weight (kgs)	Approx. Weight (lbs)
	PTFE	Neoprene	Polyurethane				
10	200	NA	NA	335	90	6	13
15	200	NA	NA	335	95	6	13
20	200	NA	NA	335	105	6	13
25	205	200	NA	315	115	7	15
40	205	200	205	345	150	10	22
50	205	200	205	355	165	12	26
65	205	200	205	390	185	17	37
80	205	200	205	390	200	17	37
100	255	250	255	410	220	22	48
125	255	250	255	410	250	24	53
150	306	300	308	469	285	35	77
200	357	350	358	527	340	45	99
250	465	462	NA	597	395	84	185
300	515	512	NA	691	445	102	225
350	565	562	NA	717	505	123	271
400	615	612	NA	757	565	147	324
500	735	732	NA	865	670	209	461
600	830	824	NA	930	780	252	555
700	925	922	NA	1075	895	352	776
800	1075	1072	NA	1190	1015	462	1018
900	1120	1112	NA	1283	1115	552	1217
1000	NA	1212	NA	1290	1230	682	1503
1200	NA	1212	NA	1577	1405	772	1701

Dimensions: in inches

Size (in inches)	Liner			B (in inches)	ANSI #150 D1 (in inches)	Approx. Weight (lbs)	ANSI #300 D1 (in inches)	Approx. Weight (lbs)
	PTFE	Neoprene	Polyurethane					
1/2"	7.87	NA	NA	13.19	3.5	13.2	3.75	*
3/4"	7.87	NA	NA	13.19	3.875	13.2	4.625	*
1"	8.07	7.87	NA	12.40	4.25	15.4	4.875	*
1.5"	8.07	7.87	8.07	13.58	5	22	6.125	*
2"	8.07	7.87	8.07	13.98	6	26.4	6.5	*
2.5"	8.07	7.87	8.07	15.35	7	37.4	7.5	*
3"	8.07	7.87	8.07	15.35	7.5	37.4	8.25	*
4"	10.04	9.84	10.04	16.14	9	48.4	10	*
5"	10.04	9.84	10.04	16.14	10	52.8	11	*
6"	12.05	11.81	12.13	18.46	11	77	12.5	*
8"	14.06	13.78	14.09	20.75	11	99	15	*
10"	18.31	18.19	NA	23.50	13.5	184.8	17.5	*
12"	20.28	20.16	NA	27.20	16	224.4	20.5	*
14"	22.24	22.13	NA	28.23	19	270.6	23	*
16"	24.21	24.09	NA	29.80	21	323.4	25.5	*
20"	28.94	28.82	NA	34.06	23.5	459.8	28	*
24"	32.68	32.44	NA	36.61	32	554.4	NA	*
28"	36.42	36.30	NA	42.32	36.5	774.4	NA	*
32"	42.32	42.20	NA	46.85	41.73	1016.4	NA	*
36"	44.09	43.78	NA	50.51	46	1214.4	NA	*
40"	NA	47.72	NA	50.79	50.75	1500.4	NA	*
44"	NA	47.72	NA	62.09	59.5	1698.4	NA	*

For meter sizes from 48" to 60" please refer factory for details.

Malema magnetic Flowmeter model MLDY Series- Compact Version											* For meter size in inch	
Model											use mm code	
MLDY	OOOOS	Meter size in mm *									Inch	mm
		(for meter size in inches please refer the adjesent table and enter mm equivalent)									1/2"	0015
		X	Electrodes								3/4"	0020
			1 SS 316								1"	0025
			2 SS316 Ti								1-1/2"	0040
			3 Hastalloy C								2"	0050
			4 Hastalloy B								2-1/2"	0065
			5 Titanium								3"	0080
			6 Tantalum								4"	0100
			7 Other								5"	0125
		X	Liner								6"	0150
			1 PTFE								8"	0200
			2 Neoprene								10"	0250
			3 Polyurethane								12"	0300
			4 Other								14"	0350
		X	Flange rating								16"	0400
			1 4.0MPa (DN 10- DN 50)								18"	0450
			2 1.6MPa (DN 65- DN 150)								20"	0500
			3 1.0Mpa (DN 65- DN 150)								24"	0600
			4 0.6MPa (DN 1200-DN 1600)								28"	0700
			5 ANSI # 300(1/2" - 8")								32"	0800
			6 ANSI #150(1/2" - 60")								36"	0900
			7 Other								40"	1000
		X	Temperature								44"	1100
			1 ≤ 45 deg C (for Polyurethane)								52"	1200
			2 ≤ 80 deg C (for Neoprene)								56"	1400
			3 ≤ 120 deg C (PTFE)								60"	1500
		X	Grounding Rings								64"	1600
			0 No grounding rings									
			1 SS 316									
			2 SS 316 Ti									
			3 Other									
		X	Protection Catogory									
			0 IP65									
			1 IP67									
		X	Current output									
			1 4-20mA									
			2 0-10mA									
		X	Frequency output									
			0 No									
			1 1kHz									
			2 2kHz									
			3 3kHz									
			4 4kHz									
			5 5kHz									
			6 Other									
		X	Digital Communication									
			0 Not Required									
			1 RS485									
			2 RS232C									
			3 HART									
		X	Power Supply									
			0 220 Vac									
			1 24 Vdc									
			2 110 Vac									
		X	Accessories									
			0 Not Required									
			1 Mating Flanges									
			2 Mounting parts									
			3 Mating flanges and Mounting parts									
Example:												
4" magmeter with PTFE lining, SS 316 electrodes, Ansi#300 flanges and SS 316 grounding rings												
MLDY	O1OOS	1	1	5	3	1	0	1	1	0	1	0

Malema magnetic Flow Sensor (Primary Head)- Separated version				* For meter size in inch use mm code	
Model					
MLDG	OOOOS	Meter size in mm *		Inch	mm
		(for meter size in inches please refer the adjacent table and enter mm equivalent)		1/2"	0015
		X Electrodes		3/4"	0020
		1 SS 316		1"	0025
		2 SS316 Ti		1-1/2"	0040
		3 Hastalloy C		2"	0050
		4 Hastalloy B		2-1/2"	0065
		5 Titanium		3"	0080
		6 Tantalum		4"	0100
		7 Other		5"	0125
		X Liner		6"	0150
		1 PTFE		8"	0200
		2 Neoprene		10"	0250
		3 Polyurethane		12"	0300
		4 Other		14"	0350
		X Flange rating		16"	0400
		1 4.0MPa (DN 10- DN 50)		18"	0450
		2 1.6MPa (DN 65- DN 150)		20"	0500
		3 1.0Mpa (DN 65- DN 150)		24"	0600
		4 0.6MPa (DN 1200-DN 1600)		28"	0700
		5 ANSI # 300(1/2" - 8")		32"	0800
		6 ANSI #150(1/2" - 60")		36"	0900
		7 Other		40"	1000
		X Temperature		44"	1100
		1 ≤ 45 deg C (for Polyurethane)		52"	1200
		2 ≤ 80 deg C (for Neoprene)		56"	1400
		3 ≤ 180 deg C (PTFE)		60"	1500
		X Grounding Rings		64"	1600
		0 No grounding rings			
		1 SS 316			
		2 SS 316 Ti			
		3 Other			
		X Protection Catogory			
		0 IP65			
		1 IP67			
		X Accessories			
		0 Not Required			
		1 Mating Flanges			
		2 Mounting parts			
		3 Mating flanges and Mounting parts			
Example:					
4" magmeter primary head with PTFE lining, SS 316 electrodes, Ansi#300 flanges and SS 316 grounding rings					
MLDG	O1OOS	1	5	3	1
		0	1	0	0

Malema Signal Converter model MLDZ Series for flow sensor model MLDG			
Model			
MLDZ-6	X	Current output	
	1	4-20mA	
	2	0-10mA	
		X Frequency output	
		0 No	
		1 1kHz	
		2 2kHz	
		3 3kHz	
		4 4kHz	
		5 5kHz	
		6 Other	
		X Digital Communication	
		0 Not Required	
		1 RS485	
		2 RS232C	
		3 HART	
		X Power Supply	
		0 220 Vac	
		1 24 Vdc	
		2 110 Vac	
Example:			
Malema Signal Converter model MLDZ Series separated version suitable for MLDY Sensor			
110 Vac power supply, 4-20mA current output and 1kHz frequency output			
MLDZ-6	1	1	0 2
Note: Remote version comes with 30 ft (10m) signal cable. Extra length needs to be ordered			

Selection:

Ideally you need to select the magnetic flow meter with its maximum flow velocity between 3-5 m/s (10-17 ft/sec). However, in some cases higher velocities are also acceptable based on the application. Please check with us for correct selection of the meter.

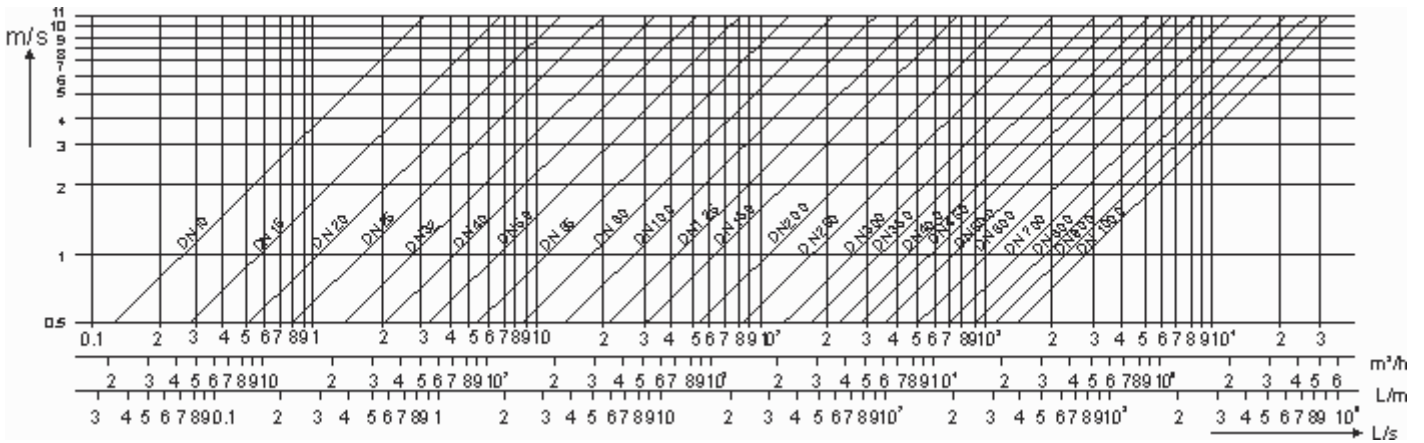

Ordering Information:

Please give us the complete information on your application details with appropriate units. We will need the following to size and quote the right flow meter for your application:

- flow rate (minimum/normal/maximum);
- operating pressure (normal/maximum);
- operating temperature (normal/maximum);
- pipe line size;
- outputs desired and mounting requirements

All specifications are subject to change. Please check the factory for latest specifications.

Represented by:
